

Community Unity

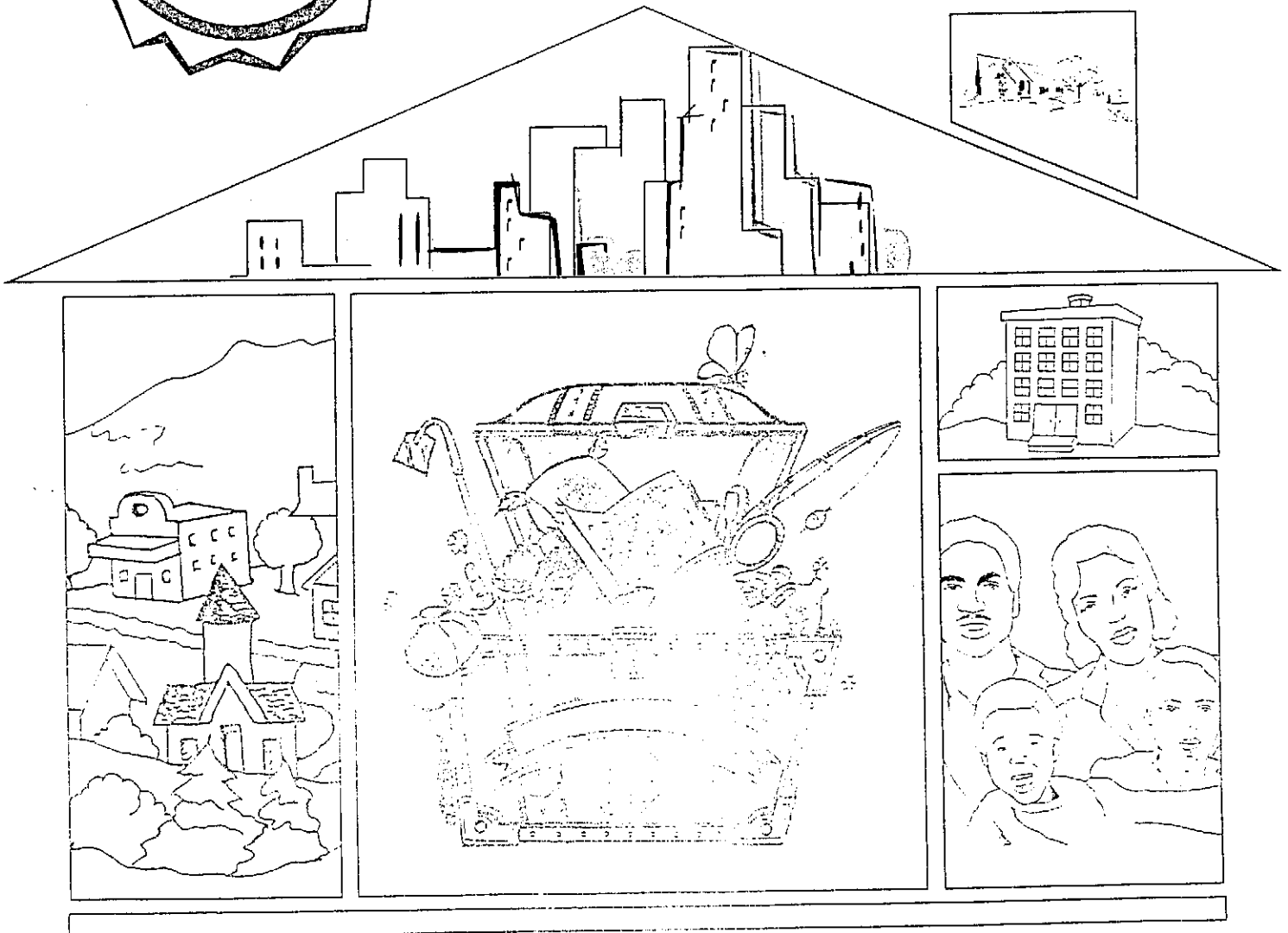

Mini-Project Book



K-3RD GRADE PROGRAM

North Carolina Cooperative Extension
North Carolina A&T State University
North Carolina State University

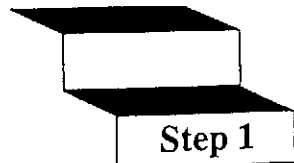

Step 1

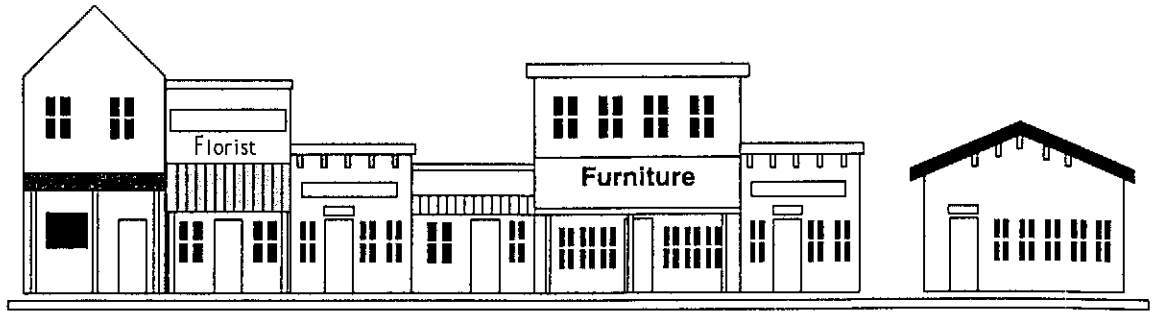

In this Mini Project you will learn:

- What makes up a community
- Different kinds of communities
- How families are like communities
- Why communities and families have rules

A Note for Parents or Guardians

This booklet is designed for 4-H'ers to use, along with a parent or guardian, in an experiential learning activity focused on families and communities. 4-H'ers will develop their motor skills and their capacities for visual discrimination. They will also gain exposure to such lifeskills as interpersonal communications, problem-solving, decision-making, planning, and "learning to learn."

An accompanying Community Unity Activity Guide provides innovative group activities, which supplement the information in this booklet and offer additional learning experiences.

Fun Things To Do

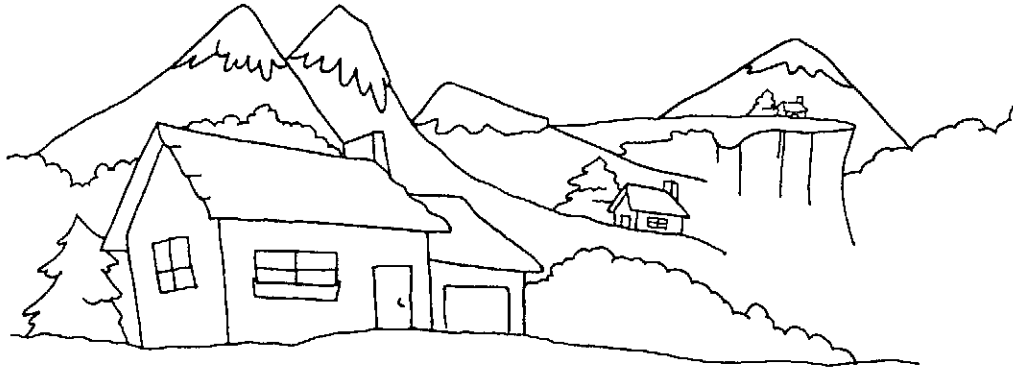

Directions for Parent and Guardians:

To the right are activities which you and your child can do together as you work your way through the Community Unity Step 1 Project Book. Before your child begins work on the Project Book, discuss these activities and check off what you hope to accomplish.

- Color drawings
- Discover different kinds of communities
- Connect dots to create a drawing
- Find out what makes up a community
- Learn community words
- Discover jobs which are important to communities
- Fill out a form about your community
- Write your address
- Find out why families are important to communities
- Practice counting
- Write the names of the people in your family
- Solve a puzzle
- Make a list of family jobs and who does them
- Learn why families and communities need rules
- Solve a maze

Many communities have places where people...

... Play ...

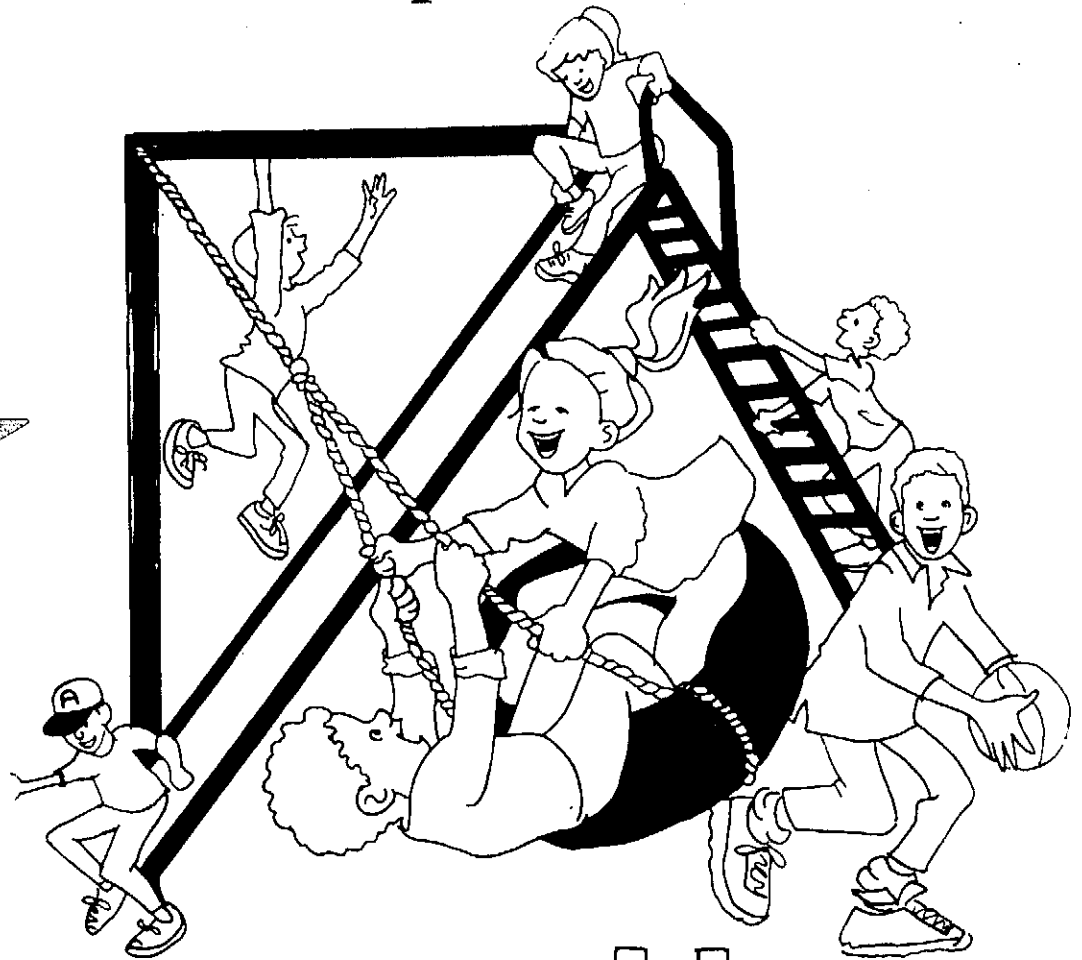

... Work ...

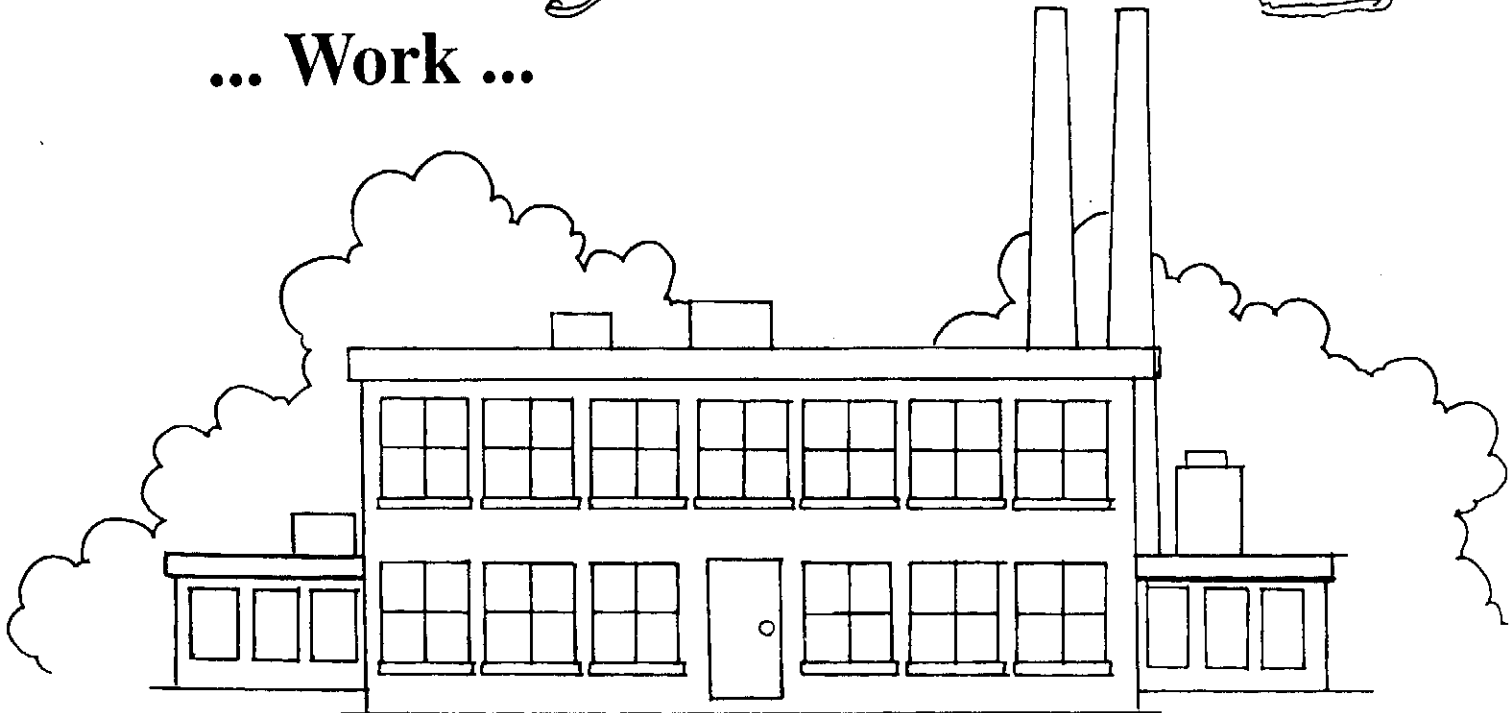

Can you name a place in your community where people work?
Can you name a park or recreation center in your community?

**In addition to homes
where people live, most
communities have...**

... Schools ...



... Churches ...

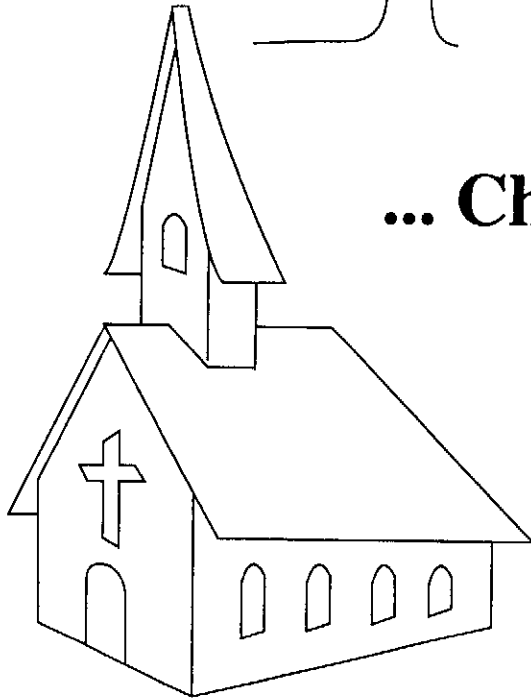

... Stores ...

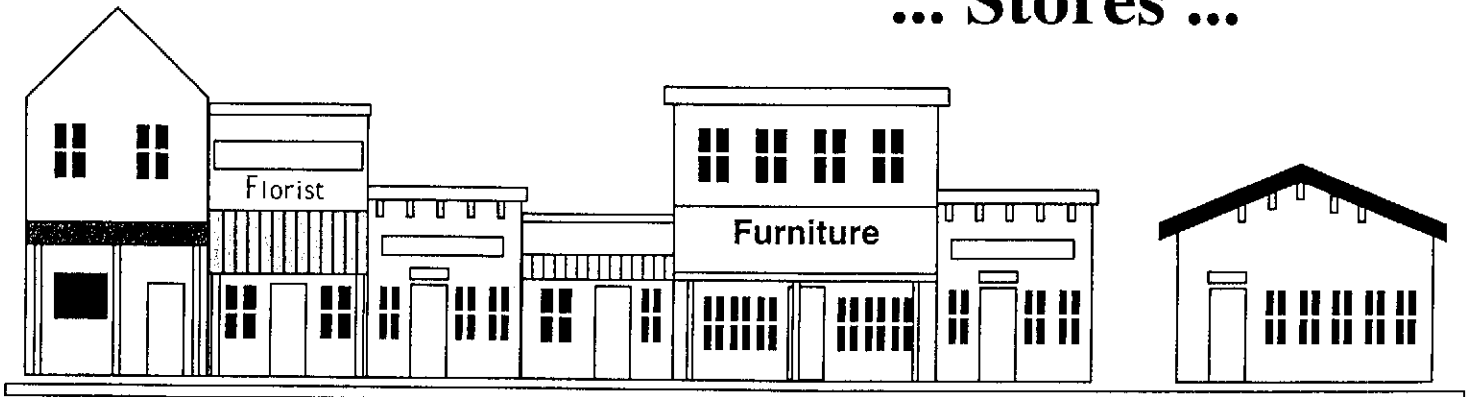

What makes up your community?

If your community has something on this list, then put a ✓ (check) in the (box) in front of it.

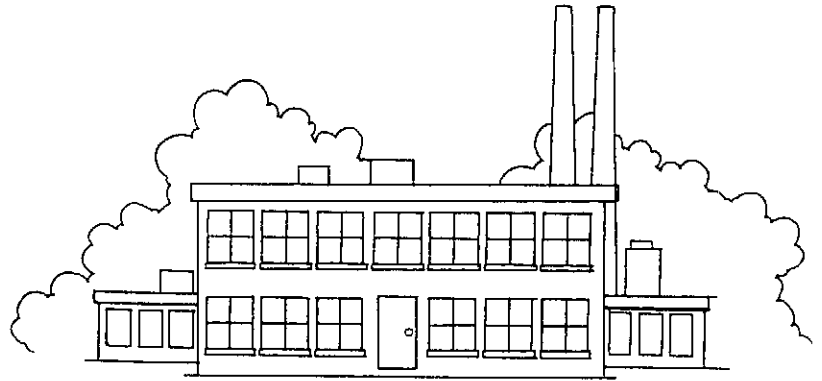
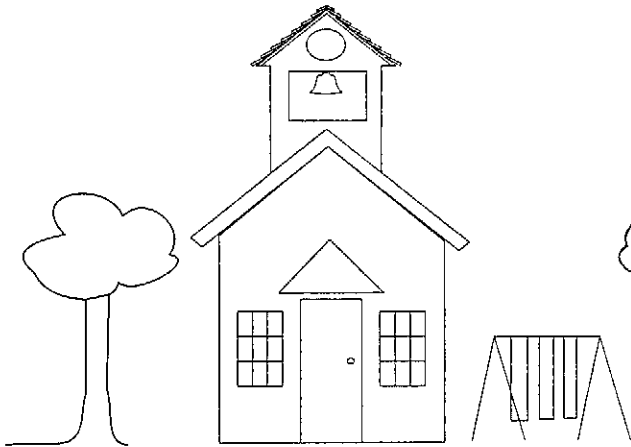

Factories, office buildings or other places where people work?

Schools?

A park or other places where people have fun?

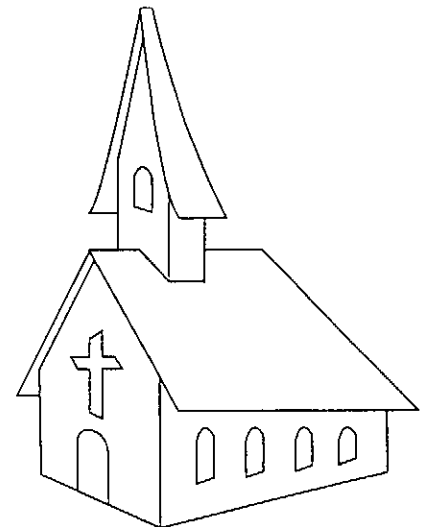
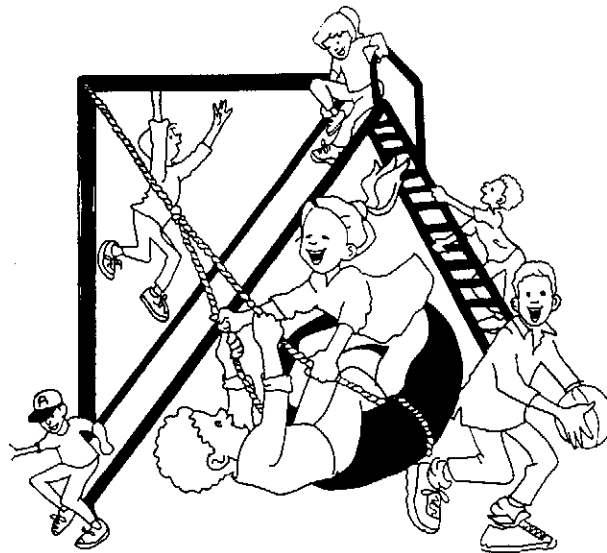

Churches?

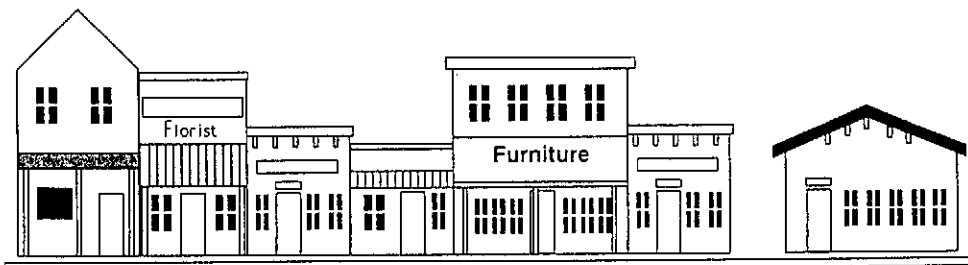

Stores?

Most communities have people whose jobs are to help other people in the community.



Nurse

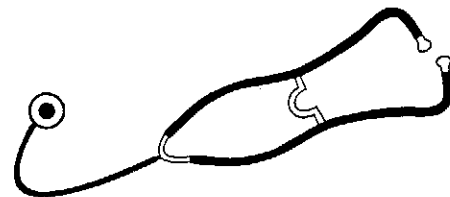
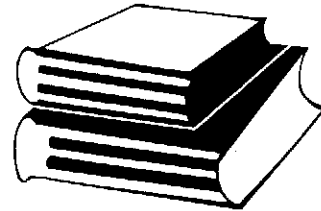

Policeman

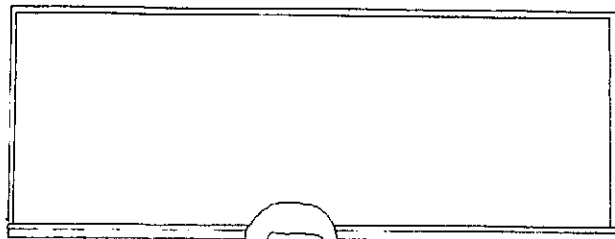

Teacher

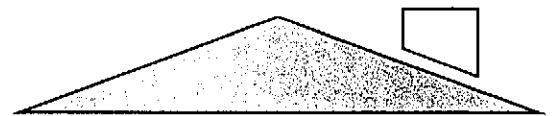

Draw lines from the people who help our communities to the tools they use.

Find the hidden community words

Home
Church

School
Store

Street
Police

Park
Business

R	I	W	N	S	D	K	T	U	Q	O	N	D	Q
Y	B	P	D	G	C	H	I	L	D	R	E	N	A
P	A	R	K	A	L	X	E	A	L	I	K	B	X
O	R	U	I	F	G	H	O	M	E	S	M	J	E
B	Y	I	L	D	C	V	W	B	I	E	Z	S	I
U	T	Y	W	O	I	D	B	D	O	G	N	B	S
Y	S	T	O	R	E	S	D	C	Z	B	N	D	W
W	T	O	H	D	B	U	S	I	N	E	S	S	N
A	D	U	L	T	S	E	O	H	D	C	S	C	B
O	K	H	D	W	A	I	D	P	O	L	I	C	E
P	W	R	C	J	D	W	Z	L	G	A	K	I	U
P	E	U	D	S	T	R	E	E	T	S	O	C	B
N	Q	O	D	C	H	U	R	C	H	E	S	Q	A
Z	U	I	D	S	O	K	V	B	N	I	E	U	S
D	R	I	D	N	C	I	W	K	A	Q	D	S	S
O	Q	Z	S	I	U	S	C	H	O	O	L	S	D

Your address usually tells what community you live in.

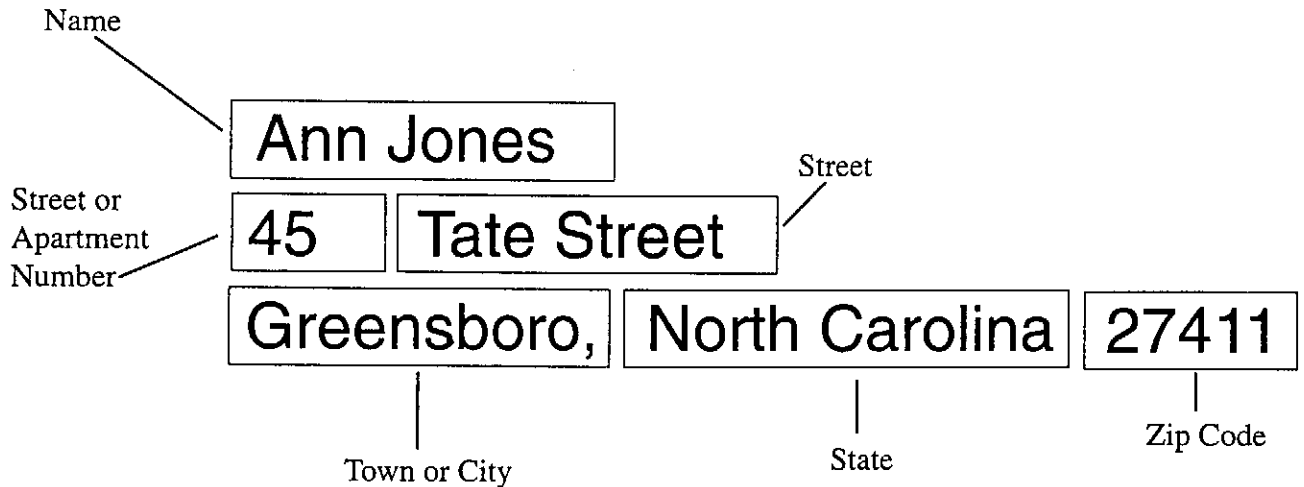

Now write your name _____

The number of your house or apartment _____

The street you live on _____

The town or city you live in _____

The state you live in _____

Your zip code _____

A Note for Parents or Guardians

If your child is not yet far enough in school for writing, please assist.

Different kinds of communities

Trace the name and then say it out loud.

T O W N



C I T Y

A small town is one kind of community. A neighborhood in a city is also a community.

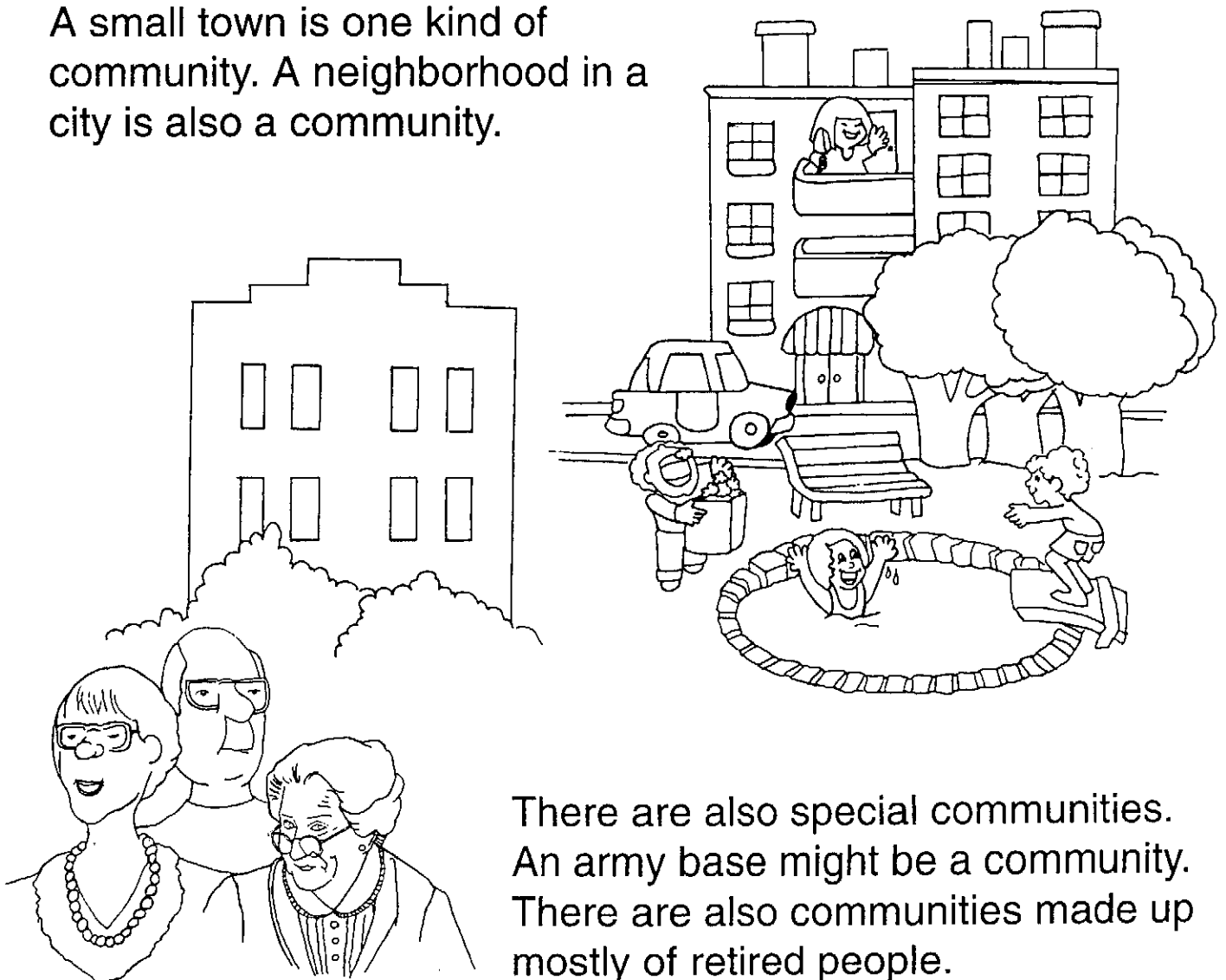

There are also special communities. An army base might be a community. There are also communities made up mostly of retired people.

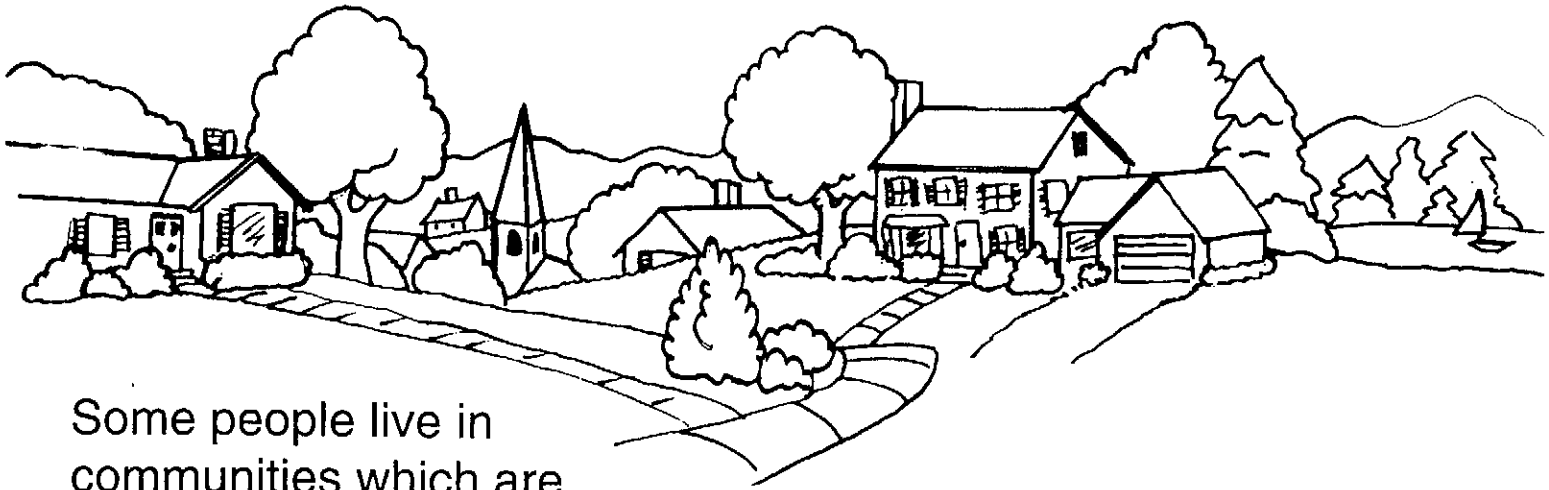

Some people live in communities which are very spread out.

In other communities, people live close together.



Circle the community which is most like the community you live in.

Not all communities have the same kinds of homes.

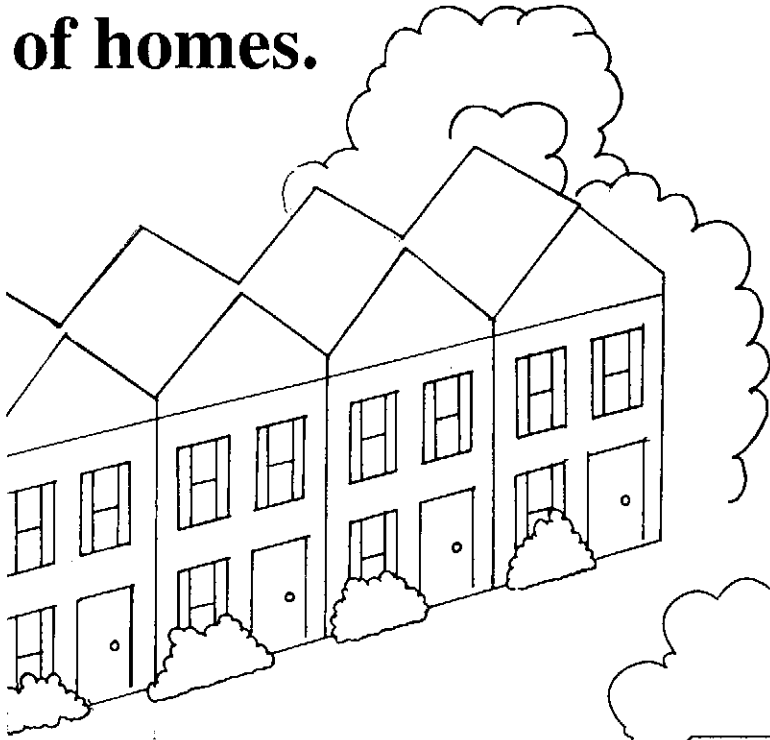

In some communities, people live in apartments.



In other communities, people live in houses.

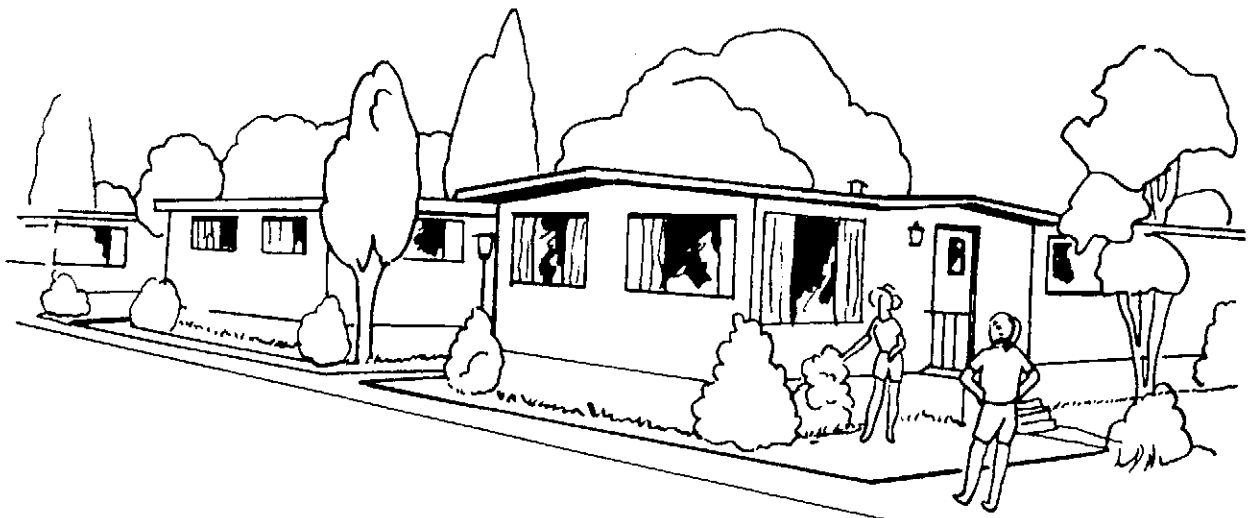

There are also communities where most people live in houses that were made in factories.

Around the world, there are many different types of communities.

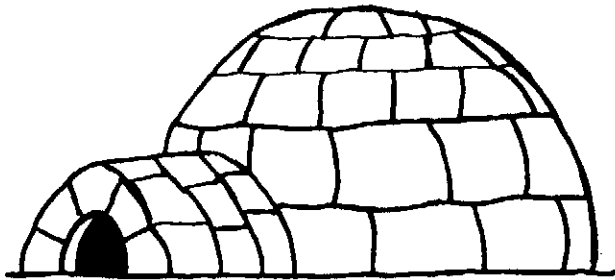

In some parts of the world, communities have houses made of ice and snow, called igloos (ig-lōz).



In some parts of the world, communities have homes made of grass and clay.

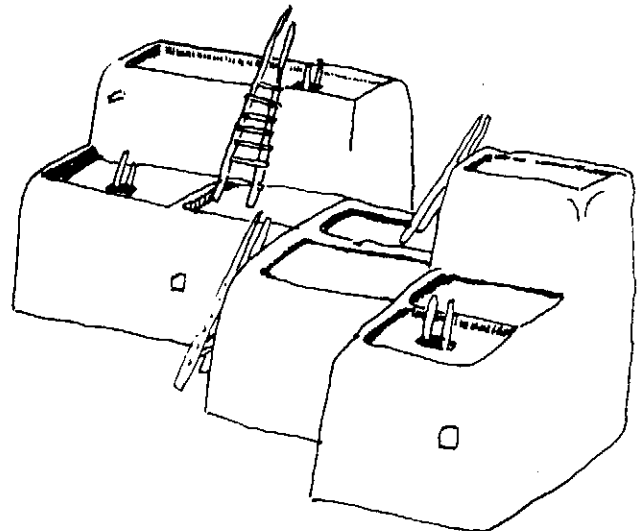
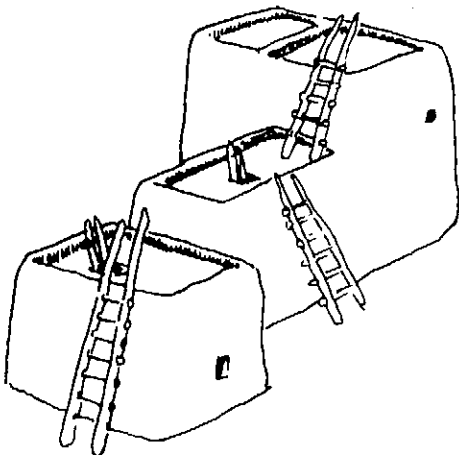
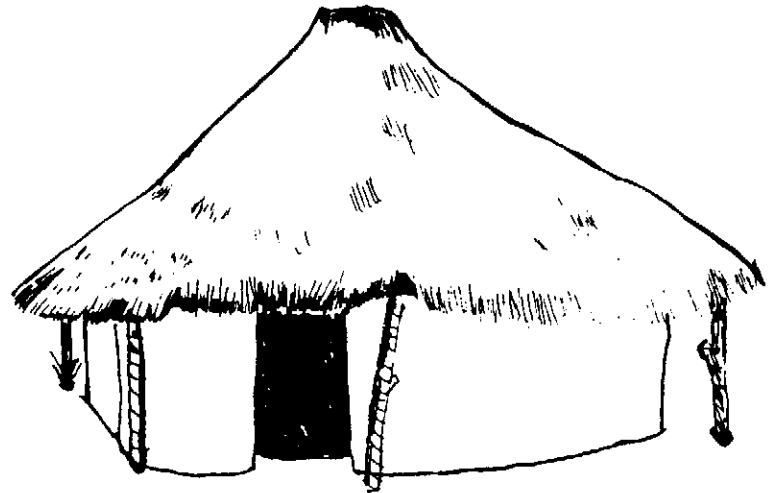

In some communities, people live in homes made of clay, which are called pueblos (pweb-lōz).

Although there are all types of communities, there is one thing you will find in all of them: Families.



And just as there are all kinds of communities, there are all kinds of families

Circle the families that have the same number of people in them.

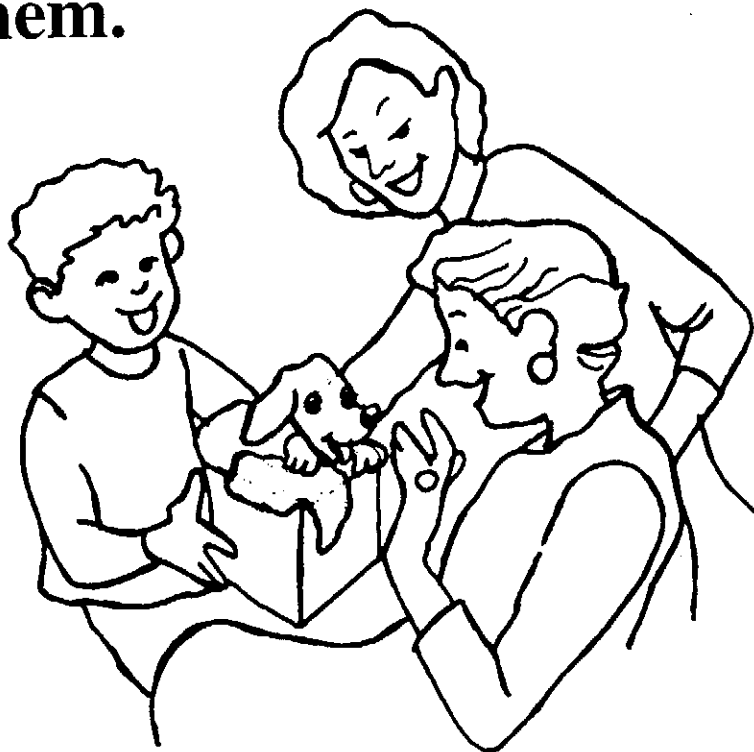

A Note for Parents or Guardians

Please discuss ways families can be different with your child, and explain to them that even though they will discover there are many different kinds of families in today's society, all of these different kinds of families give members strength and security.

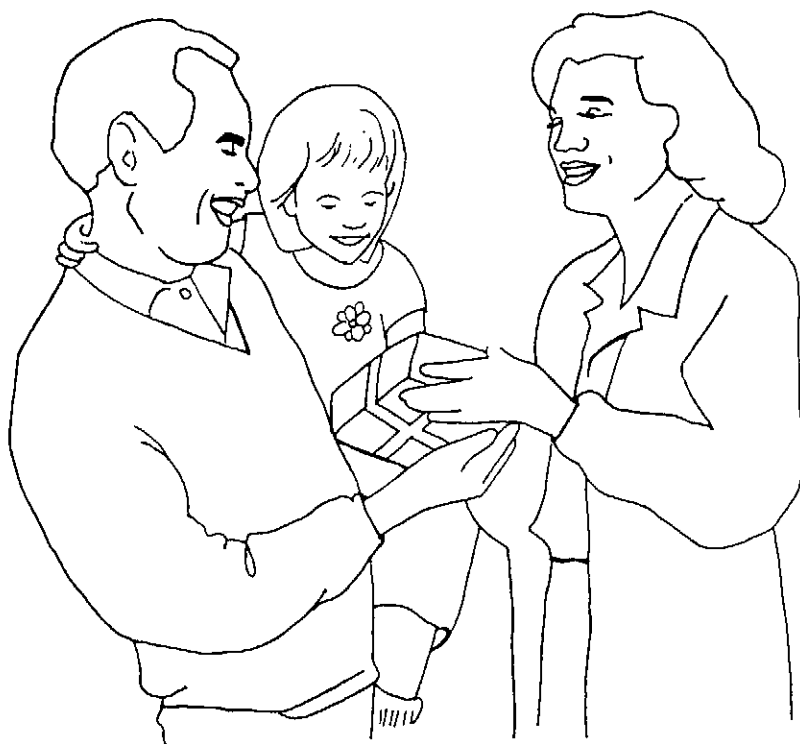

All families are special. The people in a family make it special. Special people should be treasured and loved.



Write down the names of some of the special people in your family.

Family and community responsibilities

In every community, there are jobs which must be done. Count the number of people who are doing a "community job" in this drawing.

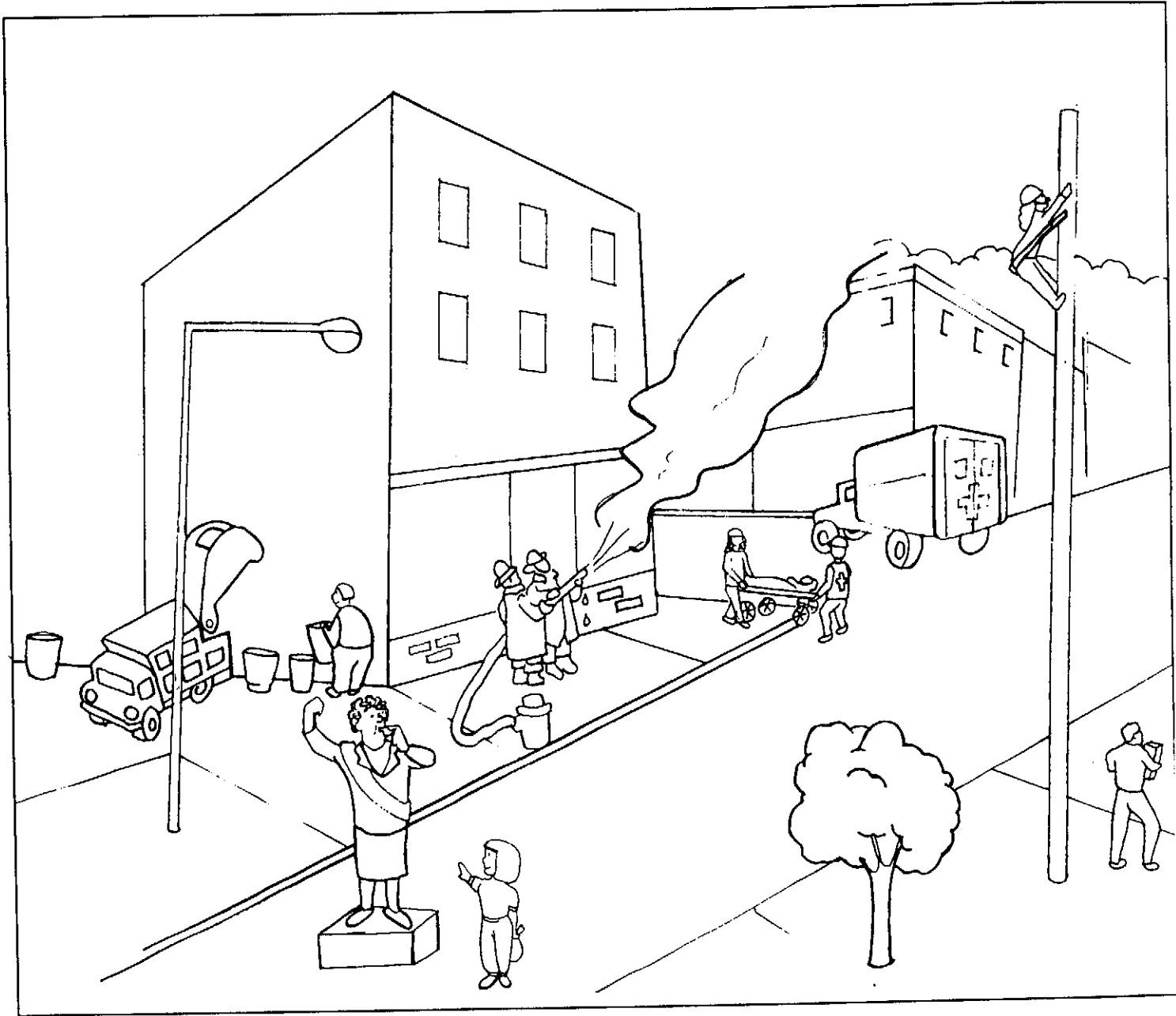

Answer key: (1.) Utility worker on a phone pole; (2) Sanitation crew loading trash into a truck; (3) Crossing guard helping children across the street; (4) Paramedics loading a stretcher into an ambulance; (5) Fireman hosing down a house fire.

There also are jobs which must be done in every family's home.

Write the names of the people who do these jobs at your home:



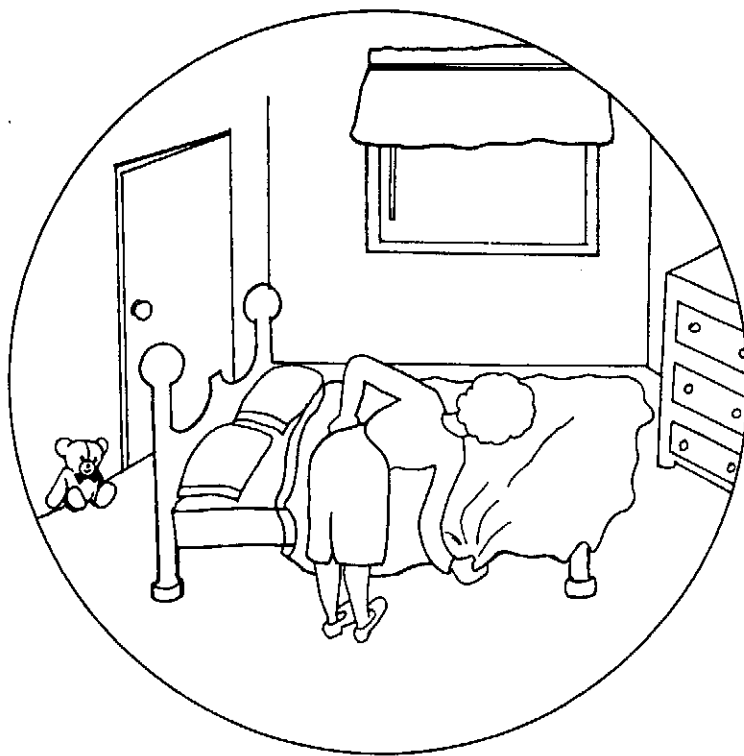

Communities have rules to keep the people who live in them from getting hurt. Rules also help people become friends.

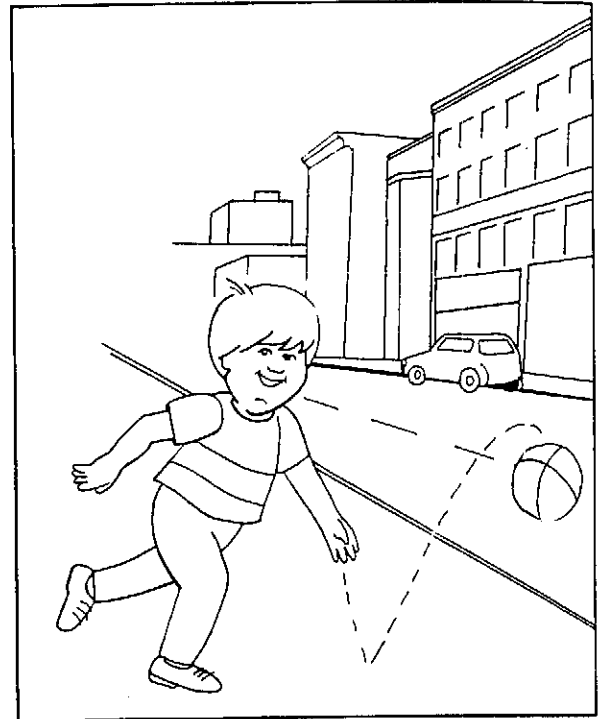
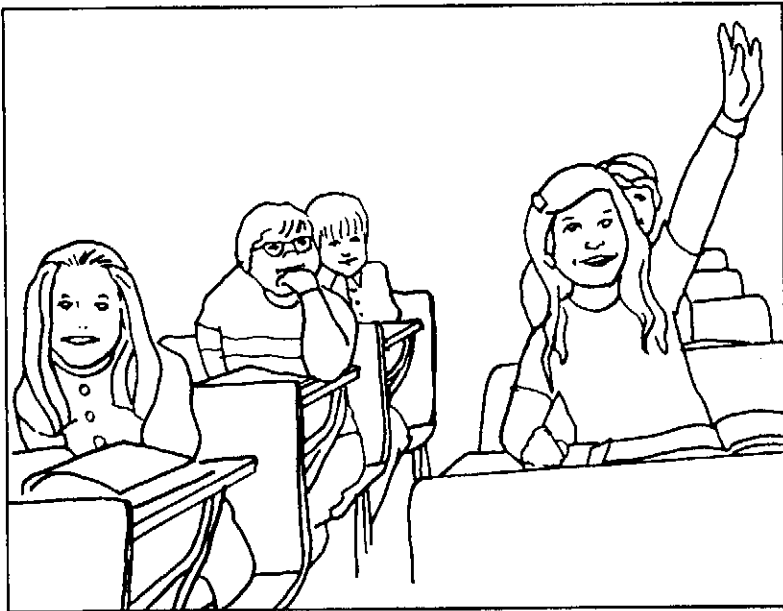

Circle the drawings in which someone is breaking a rule.

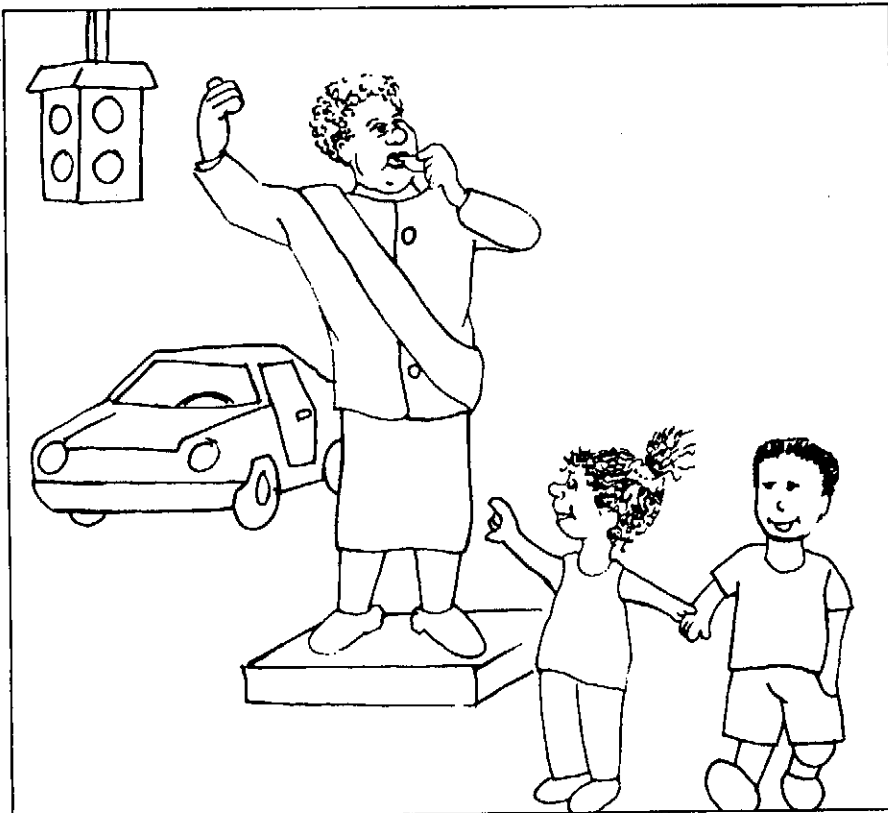

Families have rules. Some rules tell us what we should do, and other rules tell us what we should not do. Many rules keep us from getting hurt.



A Note for Parents or Guardians

Please help your child understand the importance of rules at school, home, church, and other places. Discuss your family rules and their importance.



Find your way through the maze of streets in a community.

Below is a maze of streets and stores in a make-believe community. Start at home and find your way to school. Then find your way to the grocery store. And then find your way to your grandparents' house.

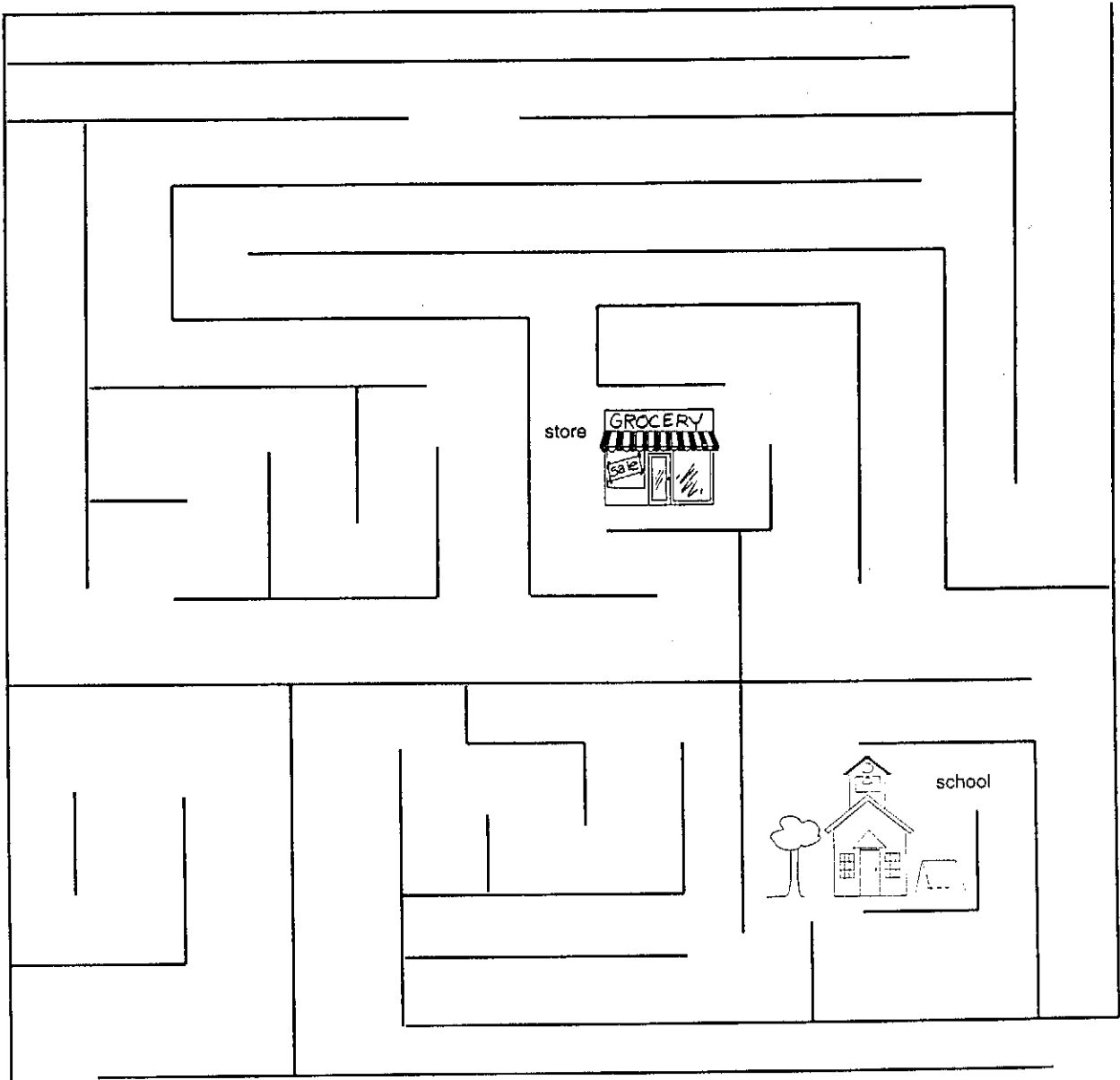

Fun Things I Did

**Directions for
Parents and
Guardians:**

**To the right are
activities which
you and your
child could
have done
together as you
worked your
way through
the Community
Unity Step 1
Project Book.
Discuss these
activities and
check off those
you were able
to do together.**

- Colored drawings
- Discovered different kinds of communities
- Connected dots to create a drawing
- Found out what makes up a community
- Learned community words
- Discovered jobs which are important to communities
- Filled out a form about my community
- Wrote out my address
- Found out why families are important to communities
- Practiced counting
- Wrote out the names of the people in my family
- Solved a puzzle
- Made a list of family jobs and who does them
- Learned why families and communities need rules
- Solved a maze

4-H'er _____

Parent/Guardian _____

Parent/Child Fun Things To Do

1. Use modeling clay to make a three-dimensional map of your neighborhood or community. Be sure to include schools, churches, stores and other buildings of significance to children.

2. Make a chart listing various family chores and the individuals responsible for them. Discuss the importance of these chores, and the importance to society of medical and public safety professions. Locate pictures in books and magazines of people at work, and discuss the ways in which other people depend on their efforts.

3. Locate your home on a map, and also locate the home of a friend or relative. Tracing the route between the two locations with your finger, help your child understand the map's basic symbols.

4. Help your child draw pictures of your community at various times of the year by supplying books and magazines with photos of seasonal weather extremes. Provide a calendar for labeling the completed drawings with the appropriate months.

5. Visit your public library, and, in the children's section, find a book about growing up in another country and culture. Then go to the cookbook section and find a cookbook with recipes from the same country as the children's book. Make sure to take your child with you when you shop for the ingredients for your ethnic cuisine, and give the child a role in preparing the meal.

6. Describe the neighborhood you lived in while growing up—show your child photographs if any are available—and compare it with the community you now live in. Suggest comparable buildings from your childhood and the community you now live in for your child to draw.

7. Use a map of your state or region to discuss vacation possibilities, and various types of transportation. Point out airports, and lakes, oceans or rivers on which there is boat travel. Show your child a rail line, a road on which the largest trucks can travel, and a gravel road unsuited to trucks.

Picture Glossary

Community: A place where people live, work and play. Many communities also have stores, schools and churches.

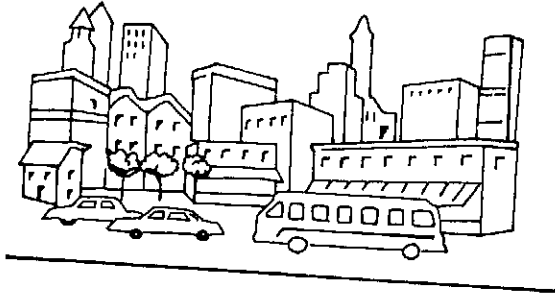

City

A very large community. There may be tall buildings in a city.

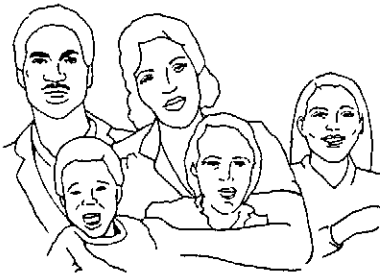

Family

A group of people who are related and live together.

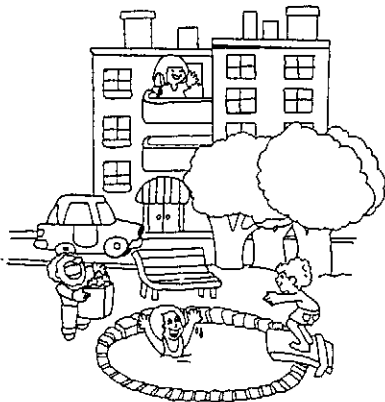

Neighborhood

The part of a community closest to where you live.

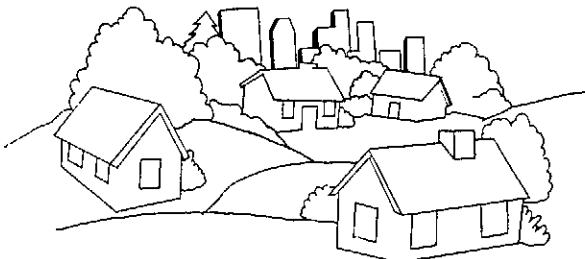

Suburb

A town or smaller city which is near a large city.



Town

A community with homes, and places to work and play, which does not have as many people as a city.

North Carolina Cooperative Extension Program

North Carolina Agricultural and Technical State University at Greensboro, North Carolina State University at Raleigh and the U.S. Department of Agriculture cooperating, Greensboro, N.C., D. D. Godfrey, Administrator. Distributed in furtherance of the Food and Agriculture Act, September 29, 1977, PL 95-113, Sec. 1444, as amended. An Equal Opportunity Employer.

North Carolina A&T State University is committed to equality of educational opportunity and does not discriminate against applicants, students, or employees based on race, color, national origin, religion, gender, age or disability. Moreover, North Carolina A&T State University is open to people of all races and actively seeks to promote racial integration by recruiting and enrolling a larger number of white students.

Community Unity Step 1

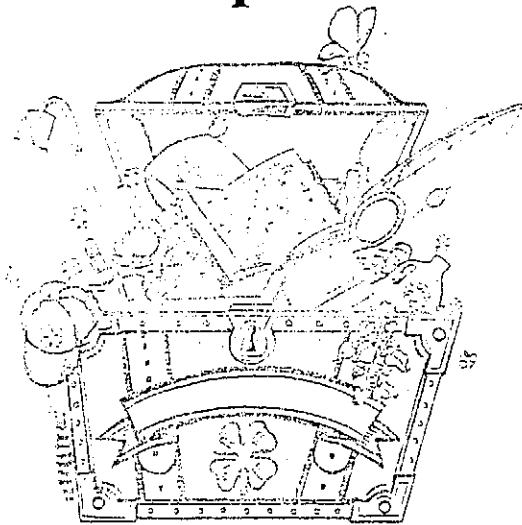

Developed by:

Stephen Lilley, Ph.D

Department of Sociology and Anthropology

North Carolina Cooperative Extension

North Carolina State University

Shirley B. Rouse, Ph.D

Extension 4-H Youth Development Specialist

North Carolina A&T State University

5000 copies of this public document were printed at a cost of \$2163.90 or 0.4328 per copy.

